

050-0106 Two-Rotor Latch With Direct Pull Actuation and Remote Inside Release

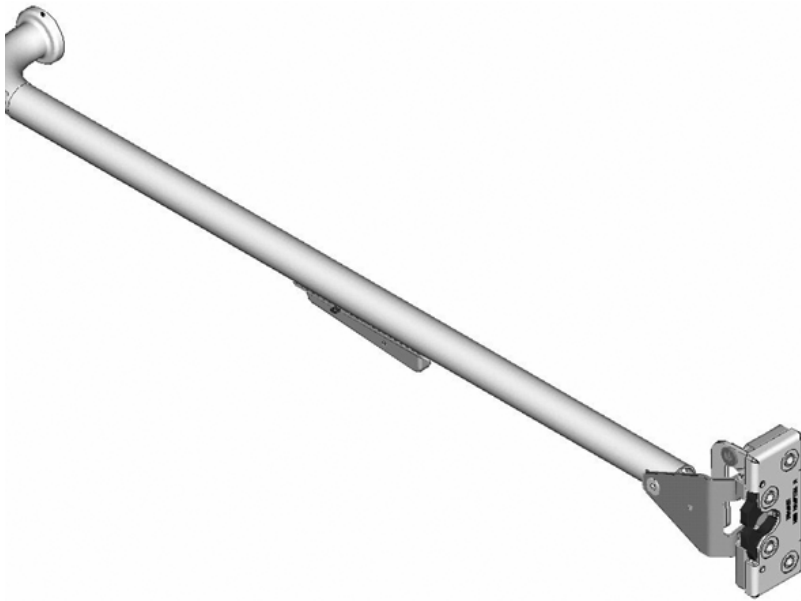

DESIGNED FOR:

- Medium to heavy weight doors for on or off-highway vehicle applications
- Doors where it is desirable to have the inside release remotely located to the latch location
- Door weights of 50-200 lbs. (23-91 kg)
- Door seal pressures of 50-100 lbs. (23-45 kg) (suggested for best results)

FEATURES/BENEFITS:

- Proven TriMark 050-0100 Two-Rotor Latch
- Latch actuator provides direct connection with TriMark 020-0800 Pull Handle
- Robust designed remote inside release is incorporated into round tubing for support for the opening and closing functions of the door
- Provides for greater ease of operation (ergonomics). The inside release can be positioned in the tube for convenient location to suit the door/cab design over direct lever releases
- The cam detail in the inside release is reversible allowing the rod or cable to be actuated in the opposite direction providing flexibility in the product application



500 Bailey Avenue
P.O. Box 350
New Hampton, Iowa 50659
United States
Tel: 641-394-3188
Fax: 641-394-2392
1-800-447-0343
www.trimarkcorp.com



TriMark Europe, Ltd.

Cedar Court
Walker Road
Bardon Hill
Coalville LE67 1TU
United Kingdom
Tel: +44 (0)1530 512460
Fax: +44 (0)1530 512461
www.trimarkeu.com



050-0106 Two-Rotor Latch With Direct Pull Actuation and Remote Inside Release

AVAILABLE:

- In left or right hand orientations (right hand shown)
- With (4) 1/4 -20 UNC or M6 x 1 threaded axles
- In 25mm steel tubing diameters, painted black
- In different tubing lengths with various inside release positions and 90 degree mounting end
- Customization is available including formed tubing (please inquire)
- As a complete modular system including exterior handle, direct release 2 rotor latch, latch striker, inside release, gaskets, mounting brackets, latch cover, door tube and all necessary fasteners

INSTALLATION:

- Easy to install - assembly is provided with tubing pre-fastened to latch that requires a single fastener at the mounting end to secure the assembly to the door
- Latch assembly - (4) 1/4 -20 UNC grade 5 or M6 x 1 class 8.8 or better fasteners are required (not included). Tighten to the fastener manufacturers' recommended torque value; however do not exceed 120 in-lbs. (13.3 N-m)
- Tubing assembly - installs with a single M6 X 1.0 bolt. Glass mounting is also possible with available mushroom window fixing designed for 5-6mm glass thickness. Recommended mounting fastener torque to be 5.6-6.7 N-m (50-59 lbf-in)

For more information visit
www.trimarkcorp.com

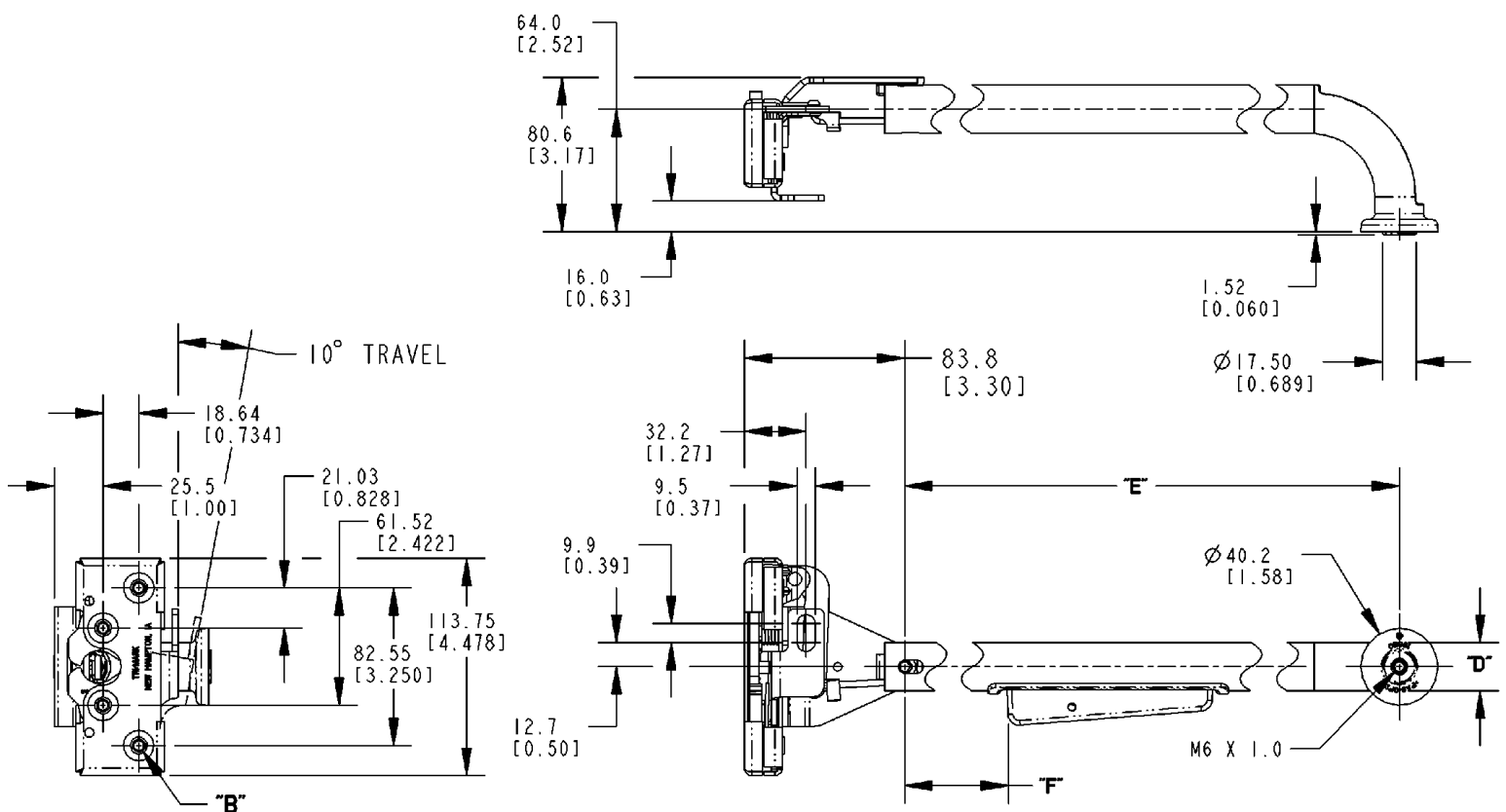

USE WITH:

- Please refer to our website for related products that are compatible for use with this product

MATERIAL/FINISH:

- Internal latch components: heat treated, smooth edge stamped steel
- Latch case halves: high strength steel
- Latch springs: non-corrosive stainless steel
- Inside release components: glass reinforced nylon
- Tube: painted steel
- Mounting end: glass-reinforced nylon with brass threaded insert
- All steel components are zinc plated, clear chromate

INTERNAL LUBRICATION:

- Oven-cured dry lubricant is applied at factory on all critical moving parts

Two position, double rotor latches comply with FMVSS 206 in primary and secondary latching positions when tested with approved TriMark FMVSS 206 compliant striker bolts in accordance with SAE J839.

CAUTION: Inside Release does not meet the locking requirements for FMVSS 206

STRIKER INSTALLATION:

- Install striker bolt in door frame
- Close door carefully and check for interference between head of striker bolt and latch components
- Add or remove shims under striker bolt washer as required (outside diameter of shim should be larger than outside diameter of striker bolt washer)
- Adjust striker bolt vertically so door is not guided upward or downward while being closed
- CHECK TO DETERMINE THAT BOTH SECONDARY AND PRIMARY LATCHING POSITIONS ARE USABLE
- Door should be latched but not "closed" in secondary position with respect to adjacent surfaces in primary position
- If both primary and secondary positions are not evident, readjust striker bolt
- After installation, check door alignment and door seal pressures

Individual part dimensions are for reference only. Refer to individual part drawings for complete dimensions, specifications, and installation procedures. Engineering assistance and application drawings are available.

Patent Pending

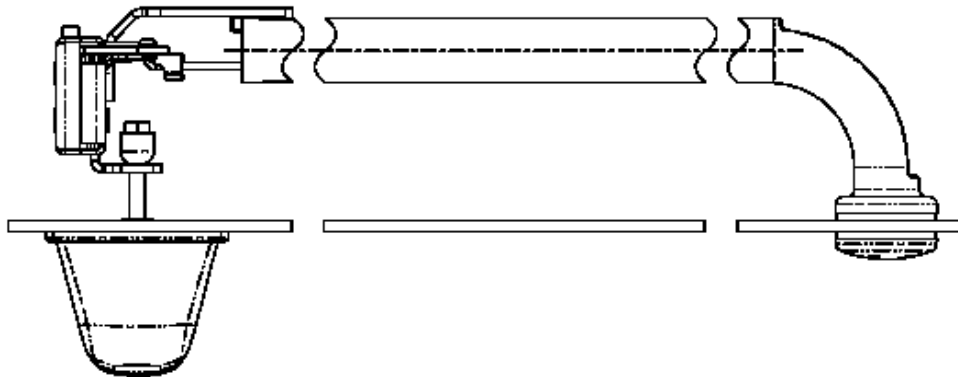

Typical System Drawing With
TriMark 020-0800 Pull Handle